

GE Lighting has been a leading supplier to Entertainment and Specialty lamp users for many decades and continues its pioneering work in the development of new and innovative light sources.

Entertainment lamps are being sold under the SHOWBIZ® brand. GE Lighting continues to provide lamps for stage, studio, nightclub and theatre lighting, to architectural and fiber optic lighting applications for this segment.

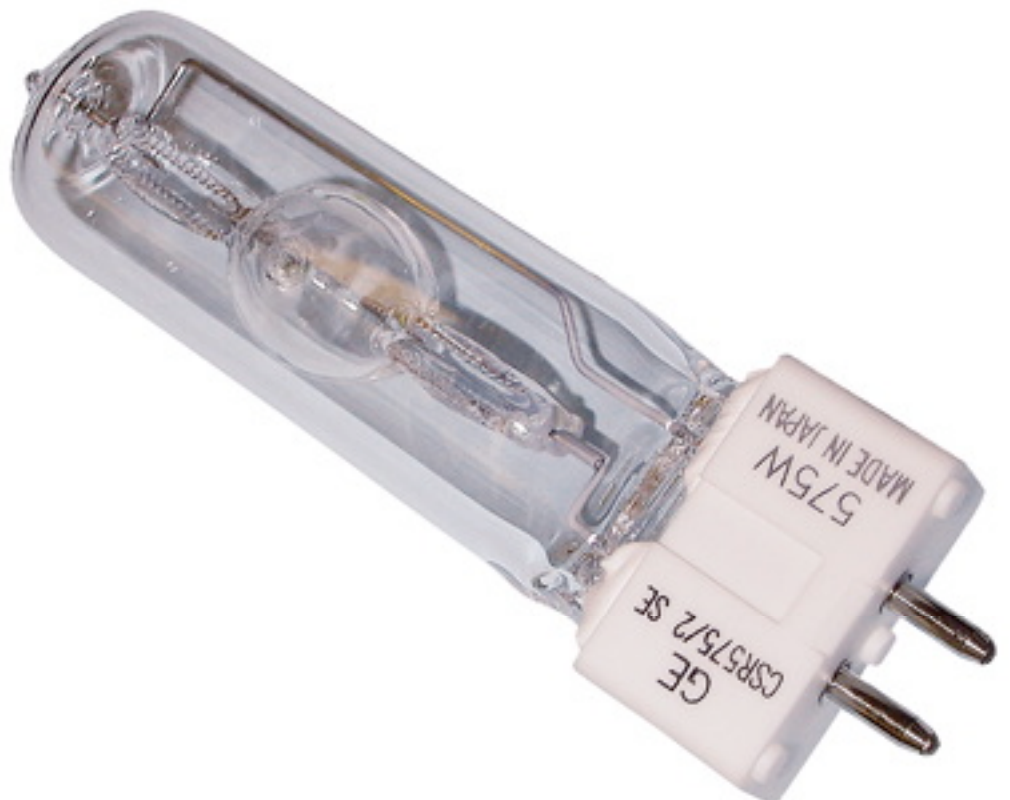

Content

PAR Lamps	144
Single Ended Halogen Lamps	148
Linear Halogen Lamps	155
Specialist Projector Lamps	150
Discharge Lamps	160
Explanation of codes	166
Incandescent tungsten halogen lamps	167
Glossary of basic product information	168



SHOWBIZ™ identification

The following glossary of terms and descriptions can help you when checking SHOWBIZ lamp specifications and when ordering products. Within each product line, lamps are divided into families - within these families, lamps are listed by wattage..

Watts:
Energy used. To find actual energy used (kWh) multiply power (watts shown) x hours of use divided by 1000

Volts:
Each lamp's voltage is listed

Colour Temp. (K):
Colour Temperature - in Kelvin. The visual warmth or coolness of the light. The higher the number the whiter or cooler the light appears

Approx Initial Lumens:
The value shown is based on spherical photometry, at rated voltage, of lamps that have been seasoned for approximately 15% (or a minimum of 2 hours) or more of their rated average life.

Filament Form:
The following codes are used for filament shape
SC - Axial Single Coil - Equivalent ANSI C8
CC - Axial Coiled Coil - Equivalent ANSI CC8
MP - Monoplane Grid - Equivalent ANSI C13
BP - Biplane Grid - Equivalent ANSI C13D
TF - Twin Monoplane Grid - Equivalent ANSI 2C13
S.C.H - Single Coil Hexagonal - equivalent to ANSI 6-C8
S.C.S - Single Coil Square - equivalent to ANSI 4-C8

Product Code:
It is important to use this code when ordering to ensure that you receive the exact product you require

Pack Quantity:
The number of lamps in one box

Dimension:
Lamp dimension in mm

Single Ended Halogen

Watt	Volt	Ansi Code	LIF Code	Lumen	CCT K	Filament	Fila. H x W	Dimension A	Dim. B	Dim. C	Life (hours)	Pack Qty	Note	Product Code	Fig. No.
G38 base (mogul prefocus)															
2500	240	-	CP94	67500	3200	BP	24x18	210	40	127	400	12	-	30500	3
3000	230	-	HX48	82000	3200	MP	24x26	210	47	127	400	12	K	30503	4
3000	240	-	HX48	82000	3200	MP	24x26	210	47	127	400	12	K	30504	4
5000	120	DPY	CP29	143000	3200	MP	31x36	280	65	165	500	6	-	41736	1

Lamp:
Description of lamp type, and product features

ANSI Code:
These are 3-letter codes assigned by the American National Standard Institute. They provide a system of assuring mechanical and electrical inter-changeability among similarly coded lamps from various manufacturers.

LIF Code:
These are assigned by the Lighting Federation of London, UK. They ensure electrical and mechanical inter-changeability of similarly coded lamps. LIF codes are divided into groups according to the primary application

Filament H & W:
Filament's size in mm

Rated Average Life:
The point in time when 50% of installed lamps are still burning

Notes:
A - Hemispherical shield in front of filament masking all direct light
B - Operate at or near horizontal
C - Protect from moisture. Safety screening techniques recommended
D - Replace broken lamp immediately. Inner bulb pressurised and could shatter unexpectedly
E - Use safety screen external to lamp
F - Operate BDTH
G - Operate BD ±30°
H - 100V rating available to order
J - 120V rating available to order
K - Specially designed for searchlight applications
L - Twin filament lamp. Lumen figures relate to single and twin filament options
M - Tungsten Halogen minimum bulb wall temp 250°C
N - 3 or 4 amp HBC fuse necessary
P - 5 or 6 amp HBC fuse necessary
Q - 6 or 7 amp HBC fuse necessary
R - 10 amp HBC fuse necessary
S - Due to internal integral reflector nominal lumens not shown
T - Obscured top
V - Due to integral dichroic reflector nominal lumens not shown
W - Axial coiled coil single ended lamps will generally give better reliability against premature arcing if orientations in which the main support spine is under the filament are avoided



PAR Lamps

PAR lamps provide a robust and flexible design solution for a wide range of theatre, studio and nightclub applications.



PAR 36



PAR 56



PAR 64

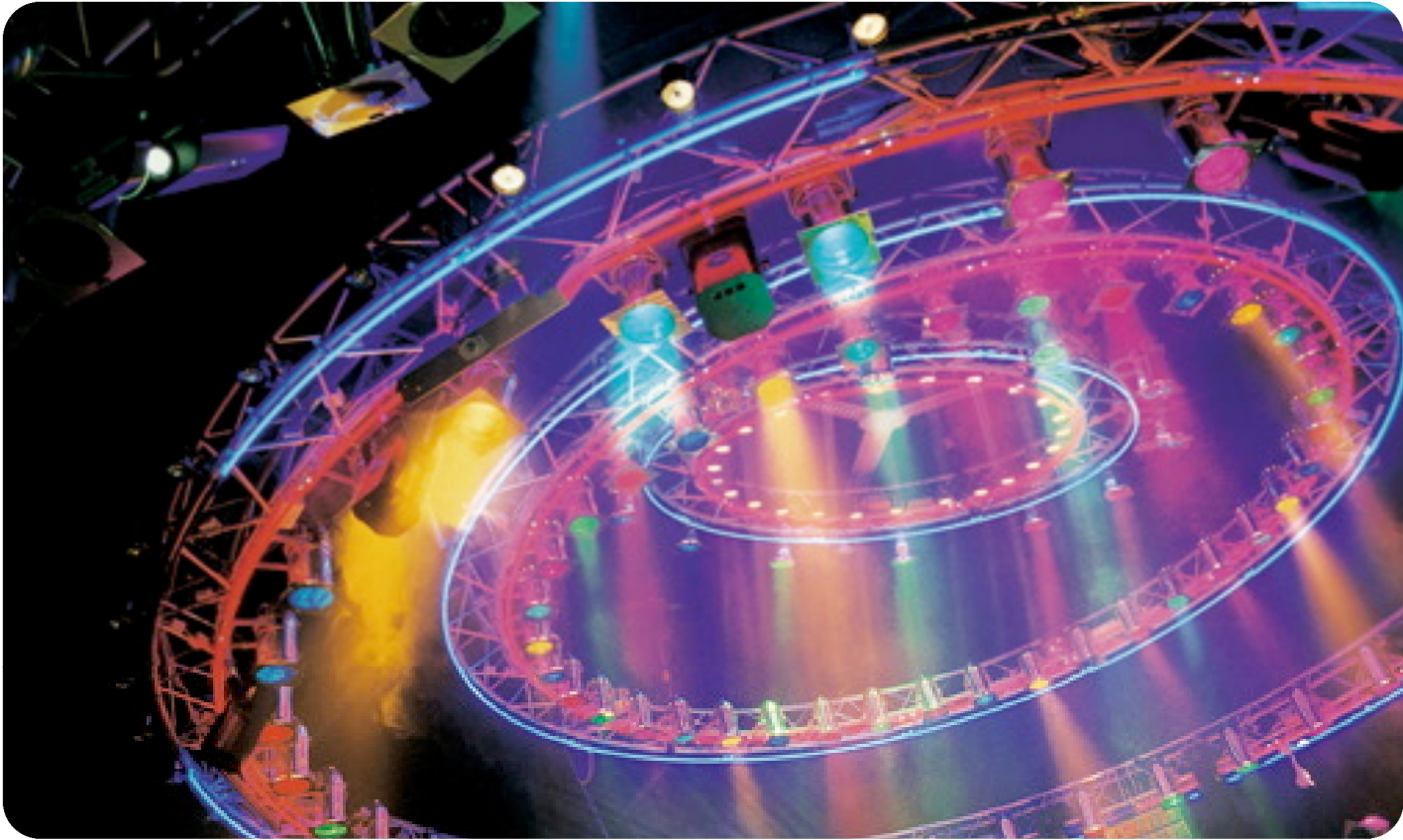

Twister, Wilhelmshafen, Germany By Fischer Art of Light & Sound GmbH, Bremen

PAR Lamps

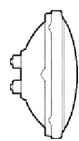

Watts	Volts	Order Code	Life (h)	Candela	Beam 10%	Beam 50%	CCT (K)	Pack Qty	Note	Product Code
PAR 36 Ferrule cap										
650	120	FCW	100	-	-	60x55	3200	12	BC	41672
650	120	FCX	100	24000	-	40x30	3200	12	BC	41673



PAR 36 Screw Terminal cap										
0.5 Amp	4.7	4546	1000	6300	3x3	-	-	12	-	24780
1.25 Amp	4.75	4547	100	20000	3x3	-	-	12	-	24788
25	5.5	25PAR36	1000	30000	5.5x4.5	-	3000	12	A	14553
25	12	25PAR36/NSP	2000	4500	19x17	10x8	-	12	A	14554
25	12	25PAR36/WFL	2000	500	49x41	37x26	-	12	A	14555
25	12	25PAR36/VWFL	2000	250	82x80	40x33	-	12	A	14556
30	12.8	4405	100	50000	6x5	-	-	12	AD	24425
30	6.2	4511	300	2300	TRAPEZOID	-	-	12	-	24663
30	6.4	H4515	100	67000	5.5x4	-	-	12	AD	15133
30	6.4	4515	100	55000	5x5	-	-	12	A	24673
50	6.4	H7604	100	100000	7x5	-	-	12	-	43576
30	6.2	4516	300	45000	9x4	-	-	12	-	24678
50	12	50PAR36/VNSP	2000	25000	11x9	-	-	12	A	12892
50	12	50PAR36/NSP	2000	9200	20x17	11x9	-	12	A	16540
50	12	50PAR36/WFL	2000	1300	48x41	36x28	-	12	A	16541
50	12	50PAR36/WFL/H	4000	-	-	-	3050	12	-	19880
50	12	50PAR36/VWFL	2000	600	80x80	40x37	-	12	A	16542
50	28	4502	400	10000	40x7	-	-	12	-	24627
50	28	4505	400	45000	11x5	-	-	12	-	24640
100	13	4509	25	110000	12x6	-	-	12	-	24650
100	13	4509X	25	110000	12x6	-	-	12	-	41503
100	28	4595	300	60000	14x16	-	-	12	-	24892
100	28	4591	25	90000	12x6	-	-	12	-	24882
50	28	4593	400	1500	80x30	-	-	12	-	24887
100	28	4594	300	70000	13x7	-	-	12	BC	24891
150	28	4626	300	25000	40x9	-	-	12	-	24964
150	28	4627	300	3000	80x30	-	-	12	-	24966
250	28	4587	25	4000	40x13	-	-	12	-	24867
250	28	4596	25	150000	11x12	-	3000	12	-	24898
650	120	DWE	100	24000	-	40x30	3200	12	BC	41667
650	120	FBE	35	35000	-	25x15	5000	12	BC	41669
650	120	FBO	30	75000	-	25x15	3400	12	BC	41671

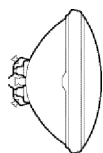

PAR 46 Screw Terminal cap										
30	6.4	4535	100	95000	5.5x4	-	-	12	A	24735
30	12.8	4435	300	75000	5x5	-	-	12	A	24577
40	12.5	4531	400	30000	20x5	-	-	12	-	24726
50	12.8	H7635	100	160000	6.5x4	-	-	12	D	43591
100	13	4537-2	25	200000	11x16	-	-	12	-	40822
100	13	4537	25	200000	11x6	-	-	12	-	24742
150	28	4570	300	32000	50x9	-	-	12	-	24828
150	28	4571	300	7000	80x25	-	-	12	-	24830
150	28	4572	300	4500	55x55	-	-	12	-	24833
250	28	4551	25	75000	50x10	-	-	12	-	24795
250	28	4553	25	300000	11x12	-	-	12	E	24799
450	28	4580	10	400000	13x14	-	-	12	-	24859
450	28	4581	10	400000	13x14	-	-	12	-	24862
450	16.5	4635	25	325000	14x15	-	-	12	-	33284
450	28	Q4554	25	65000	50x11	-	-	12	-	37706
450	28	Q4597	1000	16000	60x35	-	-	12	-	37372
450	28	Q4681	50	310000	15x9	-	-	12	-	36271

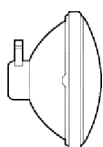

PAR 46 Medium Side Prong cap										
150	125	150PAR46/3MFL	2000	8000	39x25	26x13	2750	12	E	41968
200	120	200PAR46/3MFL	2000	11500	40x24	27x13	2750	12	E	20138

PAR Lamps

Watt	Volt	Order Code	Life (hours)	Candela	Beam 10%	Beam 50%	CCT (K)	Pack Qty	Note	Product Code
PAR 56 Screw Terminal cap										
100	12	4545	100	225000	9x5	-	-	12	A	24768
120	12	120PAR56/VNSP	2000	60000	15x10	8x6	-	12	-	19023
120	12	120PAR56/MFL	2000	19000	29x15	18x9	-	12	-	19024
120	12	120PAR56/WFL	2000	5625	50x25	35x18	-	12	-	19025
200	30	200PAR	500	270000	9x9	-	-	12	-	20122
240	12	240PAR56/VNSP	2000	140000	7x10	9x6	-	12	C	20575
240	12	240PAR56/MFL	2000	46000	28x15	18x9	-	12	C	20576
240	12	240PAR56/WFL	2000	13000	50x27	35x18	-	12	C	20577
300	12	300PAR56/WFL	1000	-	-	-	-	12	-	23427
PAR 56 GX16d cap										
300	120	300PAR56/NSP	2000	68000	20x14	10x8	2750	12	C	20803
300	120	300PAR56/MFL	2000	24000	34x19	23x11	2750	12	C	20836
300	120	300PAR56/WFL	2000	11000	57x27	37x18	2750	12	C	20849
300	230	300PAR56/NSP	2000	40000	-	-	-	12	C	20853
300	230	300PAR56/MFL	2000	30000	-	-	-	12	C	20852
300	230	300PAR56/WFL	2000	10000	-	-	-	12	C	20854
300	240	300PAR56/NSP	2000	40000	-	-	-	12	C	18676
300	240	300PAR56/MFL	2000	30000	-	-	-	12	C	18677
300	240	300PAR56/WFL	2000	10000	-	-	-	12	C	18678
500	120	Q500PAR56/NSP	4000	96000	32x15	13x8	2950	6	CD	43494
500	120	Q500PAR56/MFL	4000	43000	42x20	26x10	2950	6	CD	43495
500	120	Q500PAR56/WFL	4000	19000	66x34	44x20	2950	6	CD	43496
PAR 64 Screw Terminal cap										
250	28	4552	25	500000	8x7	-	-	12	-	40576
600	28	4559	25	600000	11x12	-	-	12	C	40578
600	28	Q4559	100	600000	12x8	-	-	12	CD	40579
600	28	Q4559X	100	765000	11x7.5	-	-	12	CD	42552

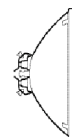
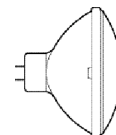
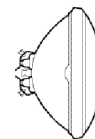

PAR Lamps

Watt	Volt	LIF Code	Order Code	Life (hours)	Candela	Beam 10%	Beam 50%	CCT K	Pack Qty	Note	Product Code
PAR 64 GX16d base (EMEP)											
500	230	CP86	Q500PAR64/VNSP	300	240000	16x13	10x7	3200	6	CD	30280
500	240	CP86	Q500PAR64/VNSP	300	240000	16x13	10x7	3200	6	CD	30282
500	230	CP87	Q500PAR64/NSP	300	140000	19x16	11x9	3200	6	CD	30283
500	240	CP87	Q500PAR64/NSP	300	140000	19x16	11x9	3200	6	CD	30286
500	230	CP88	Q500PAR64/MFL	300	65000	32x19	21x10	3200	6	CD	30287
500	240	CP88	Q500PAR64/MFL	300	65000	32x19	21x10	3200	6	CD	30288
500	230	-	500/PAR64/MFL	2000	-	32x19	21x10	2700	12	CD	39411
500	230	-	500/PAR64/W FL	2000	-	-	-	2700	12	CD	39414
1000	230	CP60	EXC SUPER	300	352000	12x9	20x17	3200	6	CD	93409
1000	240	CP60	EXC SUPER	300	352000	12x9	20x17	3200	6	CD	10925
1000	230	CP61	EXD SUPER	300	297000	14x10	22x20	3200	6	CD	10928
1000	240	CP61	EXD SUPER	300	297000	14x10	22x20	3200	6	CD	10929
1000	230	CP62	EXE SUPER	300	138000	24x11	38x20	3200	6	CD	10930
1000	240	CP62	EXE SUPER	300	138000	24x11	38x20	3200	6	CD	10931
1000	230	CP95	-	300	15000	125x95	70x70	3200	6	CD	30277
1000	240	CP95	-	300	15000	125x95	70x70	3200	6	CD	30278
1000	230	-	EXG/PAR64/WFL	300	38000	73x36	57x21	3200	6	CD	35482
1000	240	-	EXG/PAR64/WFL	300	38000	73x36	57x21	3200	6	CD	35483
500	120	-	500PAR64/NSP	2000	110000	19x14	12x7	2800	12	CD	39406
500	120	-	500PAR64/MFL	2000	37000	35x19	23x11	2800	12	CD	39409
1000	120	-	FFN	800	400000	24x10	12x6	3200	6	CD	13233
1000	120	-	FFP	800	330000	26x14	14x7	3200	6	CD	13229
1000	120	-	FFR	800	125000	44x11	28x12	3200	6	CD	13228
1000	120	-	FFS	800	40000	71x45	48x24	3200	6	CD	13227
1000	120	-	FGN	200	70000	43x20	27x11	5200	6	CD	13225
1000	120	-	Q1000PAR64/NSP	4000	200000	31x14	15x8	3000	6	CD	43497
1000	120	-	Q1000PAR64/MFL	4000	80000	45x22	28x12	3000	6	CD	43498
1000	120	-	Q1000PAR64/WFL	4000	33000	72x45	48x24	3000	6	CD	43499

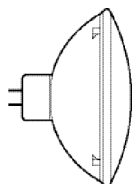

Single Ended Halogen Lamps

An extensive range of lamps designed to optimal performance in today's precision range of stage, studio and architectural luminaires.

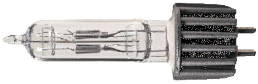

HPL



OC 1200



12K GX38



SINGLE ENDED HALOGEN LAMPS

Watt	Volt	Order Code	Lumen	CCT K	Filament	Fila. H x W	Dimension A	Dim. B	Dim. C	Life (hours)	Pack Qty	Product Code	Fig. No.
High Performance Lamps													
575	230	HPL 575	14900	3200	SCH	10 x 9.5	106	18	60.3	300	12	37128	1
575	240	HPL 575	14900	3200	SCH	10 x 9.5	106	18	60.3	300	12	37131	1
575	120	HPL 575-C	16520	3250	SCS	9 x 6	106	18	60.3	300	12	92433	2
575	115	HPL 575-C	16520	3250	SCS	9 x 6	106	18	60.3	300	12	92431	2
575	230	HPL 575-X LL	11780	3050	SCH	12 x 9.5	106	18	60.3	1500	12	37817	1
575	240	HPL 575-X LL	11780	3050	SCH	12 x 9.5	106	18	60.3	1500	12	37818	1
575	120	HPL 575-C LL-X	12360	3050	SCS	11 x 6	106	18	60.3	2000	12	92435	2
575	115	HPL 575-C LL-X	12360	3050	SCS	11 x 6	106	18	60.3	2000	12	92434	2
750	230	HPL 750	19750	3200	SCH	11.5 x 9.5	106	18	60.3	300	12	37824	1
750	240	HPL 750	19750	3200	SCH	11.5 x 9.5	106	18	60.3	300	12	37826	1
750	115	HPL 750-C	22000	3250	SCS	10.5 x 6.3	106	18	60.3	300	12	92432	2
750	115	HPL 750-C-XLL	16400	3050	SCS	13 x 6.3	106	18	60.3	2000	12	92770	2
750	230	HPL 750-X-LL	15600	3050	SCH	13 x 8	106	18	60.3	1500	12	92768	1
750	240	HPL 750-X-LL	15600	3050	SCH	13 x 8	106	18	60.3	1500	12	92769	1

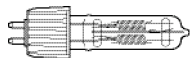

Fig. 1

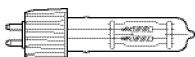

Fig. 2

Watt	Volt	ANSI Code	Order Code	Lumen	CCT K	Filament	Fila. H x W	Dimension A	Dim. B	Dim. C	Life (hours)	Pack Qty	Note	Product Code	Fig. No.
G9.5 base															
500	120	EHD	-	10000	2900	CC-8	18x5	105	20	60.5	2000	24	W	39768	1
575	115	FLK	HX600	16500	3200	CC-8	12.7x6	105	18	60.5	300	24	W	11450	1
575	115	FLK/LL	-	12800	3100	CC-8	13.7x6	105	18	60.5	1500	50	W	39730	1
600	230	GKV	HX600	14000	3200	C13-D	13.5x7.5	105	18	60.5	250	24	-	39739	2
600	240	GKV	HX600	14000	3200	C13-D	13.5x7.5	105	18	60.5	250	24	-	39750	2
600	230	GKV/LL	-	11000	3000	C13-D	16x8	105	18	60.5	1500	24	-	39751	2
600	240	GKV/LL	-	11000	3000	C13-D	16x8	105	18	60.5	1500	24	-	39752	2
650	230	FKR	-	15000	3100	CC-8	24x5	105	20	60.5	300	24	W	39734	1
650	240	FKR	-	15000	3100	CC-8	24x5	105	20	60.5	300	24	W	39735	1
750	120	EHF	-	20000	3200	CC-8	19x7	105	20	60.5	300	24	W	39771	1
750	120	EHG	-	15000	3000	CC-8	19x7	105	20	60.5	2000	24	W	39770	1
800	230	-	HX800	20000	3200	C13-D	15.8x8.4	105	18	60.5	250	24	-	39753	2
800	240	-	HX800	20000	3200	C13-D	15.8x8.4	105	18	60.5	250	24	-	39754	2
1000	120	FEL	CP77	27500	3200	CC-8	19x7	105	20	60.5	300	24	W	39769	1
1000	230	FEP	CP77	25000	3200	CC-8	24x7	105	20	60.5	300	24	W	39738	1
1000	240	FEP	CP77	25000	3200	CC-8	24x7	105	20	60.5	300	24	W	39736	1

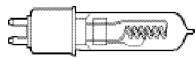

Fig. 1

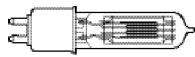

Fig. 2

SINGLE ENDED HALOGEN LAMPS

Watt	Volt	LIF Code	Order Code	Lumen	CCT K	Filament	Fila. H x W	Dimension A	Dim. B	Dim. C	Life (hours)	Pack Qty	Note	Product Code	Fig. No.
GY9.5 base - Grid-form Filament															
300	120	CP81	FKW	6900	3200	S	15x10	90	25	46	50	24	-	39781	1
300	230	CP81	FSL	6900	3200	S	11x10	90	25	46	150	24	-	39780	1
300	240	CP81	FSK	6900	3200	S	11x10	90	25	46	150	24	-	39779	1
500	120	CP82	FRG	13000	3200	MP	12.5x11.5	90	25	46	150	24	-	39623	1
500	230	CP82	FRH	12500	3200	MP	13x13	90	25	46	150	24	-	39624	1
500	240	CP82	FRJ	12500	3200	MP	13x13	90	25	46	150	24	-	39628	1
500	230	T18	GCV	11000	3050	MP	13.5x13	90	23	46	400	24	-	39717	1
500	240	T18	GCW	11000	3050	MP	13.5x13	90	23	46	400	24	-	39629	1
500	230	T25	GCV	11000	3000	BP	11x11	90	23	46.5	360	24	-	39455	1
500	240	T25	GCW	11000	3000	BP	11x11	90	23	46.5	360	24	-	39262	1
650	230	T27	GCT	14500	3050	BP	13x11	90	23	46.5	400	24	-	39456	1
650	240	T27	GCS	14500	3050	BP	13x11	90	23	46.5	400	24	-	39457	1
650	120	T26	FRE	15500	3100	MP	13.5x13.5	90	23	46	500	24	-	39630	1
650	230	T26	GCT	15500	3100	MP	15.5x13.5	90	23	46	400	24	-	39635	1
650	240	T26	GCS	15500	3100	MP	15.5x13.5	90	23	46	400	24	-	39636	1
650	120	CP89	FRK	16900	3200	MP	12.5x11.5	90	25	46	200	24	-	39637	1
650	230	CP89	FRL	16250	3200	MP	13x13	90	25	46	150	24	-	39640	1
650	240	CP89	FRM	16250	3200	MP	13x13	90	25	46	150	24	-	39642	1

S = Staggered Filament Burning position VBD ±90

GY9.5 base - Coiled Coil Filament															
600	120		FMR	12600	3050	CC-8	16x6	85	16	51	2000	24	W	30475	2

Watt	Volt	LIF Code	Order Code	Lumen	CCT K	Filament	Fila. H x W	Dimension A	Dim. B	Dim. C	Life (hours)	Pack Qty	Note	Product Code	Fig. No.
GX9.5 base															
650	230	T12	-	13500	3000	MP	15.5x14.5	110	25	55	750	12	-	39661	2
650	240	T12	-	13500	3000	MP	15.5x14.5	110	25	55	750	12	-	39663	2
650	230	CP23	-	16900	3200	MP	12x14.5	110	25	55	100	12	-	39654	2
650	240	CP23	-	16900	3200	MP	12x14.5	110	25	55	100	12	-	39660	2
1000	230	CP24	-	26000	3200	MP	18.5x17.5	110	35	55	200	12	-	39651	1
1000	240	CP24	-	26000	3200	MP	18.5x17.5	110	35	55	200	12	-	39653	1
1000	115/120	T11	Q1000T8/CL	23500	3050	MP	16x14	110	35	55	750	24	-	29331	1
1000	230	T11	-	23000	3050	MP	17.5x17.5	110	35	55	750	12	-	39656	1
1000	240	T11	-	23000	3050	MP	17.5x17.5	110	35	55	750	12	-	39659	1
1000	230	T19	FWP	21000	3050	BP	15x12	110	35	55	750	12	HJ	39657	2
1000	240	T19	FWR	21000	3050	BP	15x12	110	35	55	750	12	HJ	39658	2
1000	230	CP70	FVA	25000	3200	BP	15x12	110	35	55	200	12	HJ	39241	2
1000	240	CP70	FVB	25000	3200	BP	15x12	110	35	55	200	12	HJ	39242	2
1200	120	T29	-	30500	3050	BP	15x13	125	35	67	400	12	-	39647	3
1200	230	T29	FWS	29000	3050	BP	16x13	125	35	67	400	12	-	39723	3
1200	240	T29	FWT	29000	3050	BP	16x13	125	35	67	400	12	-	39667	3
1200	230	CP90	-	33000	3200	BP	16x12	125	35	67	200	12	J	39724	3
1200	240	CP90	-	33000	3200	BP	16x12	125	35	67	200	12	-	39725	3

Burning position VBD ±90

GY16 base															
2000	230	CP43	FTM	54000	3200	MP	22x22.5	145	40	70	400	12	-	20309	1
2000	240	CP43	FTL	54000	3200	MP	22x22.5	145	40	70	400	12	-	20310	1
2000	120	CP79	-	56000	3200	BP	17.5x16	145	40	70	400	12	-	13053864	1
2000	230	CP79	-	54000	3200	BP	18.5x17	145	40	70	350	12	H	30497	1
2000	240	CP79	-	54000	3200	BP	18.5x17	145	40	70	350	12	-	30498	1

Burning position VBD ±90

G22 Low Voltage															
1200	80		OC1200	37500	3300	BP	10.5x12.5	140	26	63.5	300	12	-	91580	2

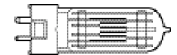

Fig. 1

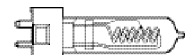

Fig. 2

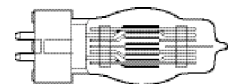

Fig. 1

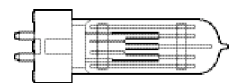

Fig. 2

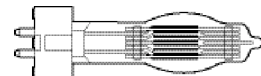

Fig. 3



Fig. 1



Fig. 2

SINGLE ENDED HALOGEN LAMPS

Watt	Volt	Ansi Code	LIF Code	Lumen	CCT K	Filament	Fila. H x W	Dimension A	Dim. B	Dim. C	Life (hours)	Pack Qty	Note	Product Code	Fig. No.
G22 base															
500	120	EGN	-	13000	3200	MP	12x11.5	140	21	63.5	150	12	-	30373	2
650	230	FKH	CP39	16900	3200	MP	12x14.5	140	25	63.5	100	12	-	20320	2
650	240	FKH	CP39	16900	3200	MP	12x14.5	140	25	63.5	100	12	-	20321	2
1000	120	EGT	-	28500	3200	MP	14.5x14	140	22	63.5	250	12	-	39191	2
1000	230	FKJ	CP40	26000	3200	MP	18.5x17.5	140	26	63.5	200	12	-	39655	2
1000	240	FKJ	CP40	26000	3200	MP	18.5x17.5	140	26	63.5	200	12	-	20286	2
1200	240	-	CP93	33000	3200	BP	16x12	140	35	63.5	200	12	-	30384	3
2000	120	-	CP92	55000	3200	BP	18x17	175	40	90	400	12	-	30391	4
2000	230	-	CP92	52000	3200	BP	18.5x17	175	40	90	400	12	-	30394	4
2000	240	-	CP92	52000	3200	BP	18.5x17	175	40	90	400	12	-	30397	4
2500	230	-	CP91	67500	3200	BP	24x18	175	40	90	400	12	-	30415	4
2500	240	-	CP91	67500	3200	BP	24x18	175	40	90	400	12	-	30423	4

Burning position VBD ±90

P28s base (medium prefocus)

500	120	EGE	-	10450	2950	CC-8	18x5	152	13	88.9	2000	12	-	39135	2
500	120	BTM	-	13000	3200	MP	12x11.5	130	21	55.5	150	12	-	16465	5
500	230	FKF	T17	9500	2950	MP	13.5x14.5	130	21	55.5	750	12	-	30535	5
500	240	-	T17	9500	2950	MP	13.5x14.5	130	21	55.5	750	12	-	30536	5
500	230	-	T28	11000	3000	MP	15x12	130	12	55.5	300	12	-	39731	5
500	240	-	T28	11000	3000	MP	15x12	130	21	55.5	300	12	-	39733	5
650	230	FKB	T13	13500	3000	MP	15.5x14.5	130	25	55.5	750	12	-	30541	3
650	240	-	T13	13500	3000	MP	15.5x14.5	130	25	55.5	750	12	-	30542	3
650	230	FKM	CP51	16900	3200	MP	12x14.5	130	25	55.5	200	12	-	20323	3
650	240	-	CP51	16900	3200	MP	12x14.5	130	25	55.5	200	12	-	20324	3
1000	120	EGJ	-	27500	3200	CC-8	19x7	152	20	88.9	500	12	W	38853	2
1000	230	EWE	-	26500	3200	CC-8	24x6	152	20	88.9	250	12	W	30533	2
1000	230	FKD	T14	23000	3050	MP	17.5x17.5	130	35	55.5	750	12	-	20385	4
1000	240	EWE	-	26500	3200	CC-8	24x6	152	20	88.9	250	12	W	30534	2
1000	240	-	T14	23000	3050	MP	17.5x17.5	130	35	55.5	750	12	-	20388	4
1000	240	FKE	T15	23000	3050	MP	17.5x17.5	160	35	88.9	750	12	-	30532	1
1000	240	FKN	CP52	26000	3200	MP	18.5x17.5	130	35	55.5	200	12	-	30546	4

Burning position VBU ±90

G38 base (mogul prefocus)

1000	230	-	HX270	25000	3200	BP	15x12	216	35	127	200	12	-	35234	3
1000	240	-	HX270	25000	3200	BP	15x12	216	35	127	200	12	-	35233	3
2000	120	CYX	HX270	59000	3200	MP	21.5x20.5	216	32	127	400	6	-	36636	3
2000	230	FKK	CP41	54000	3200	MP	22x22.5	216	32	127	400	12	-	31844	3
2000	240	FKK	CP41	54000	3200	MP	22x22.5	216	32	127	400	12	-	31849	3
2500	230	-	CP94	67500	3200	BP	24x18	210	40	127	400	12	-	30499	3
2500	240	-	CP94	67500	3200	BP	24x18	210	40	127	400	12	-	30500	3
3000	230	-	HX48	82000	3200	MP	24x26	210	47	127	400	12	K	30503	4
3000	240	-	HX48	82000	3200	MP	24x26	210	47	127	400	12	K	30504	4
5000	120	DPY	CP29	143000	3200	MP	31x36	280	65	165	500	6	-	41736	1
5000	230	-	CP29	135000	3200	MP	36x33	280	65	165	500	12	-	30505	1
5000	240	-	CP29	135000	3200	MP	36x33	280	65	165	500	12	-	30506	1
10000	220/230	-	CP83	280000	3200	MP	38x56	405	85	254	250	1	-	12036	2
10000	240	-	CP83	280000	3200	MP	39x56	405	85	254	250	1	-	12037	2

Burning position VBD ±90 except HX48 VBD ±45

Watt	Volt	Order code	Lumen	CCT K	Filament H x W	Fila.	Dimension A	Dim. B	Dim. C	Life (hours)	Pack Qty	Note	Product Code	Fig. No.	
GX38 base – Single-ended High Wattage Halogen Lamps															
12000	230	Q12MT26/4CL	420000	3400	MP	37x56	410	254	85	130	1	-	48771	1	
12000	240	Q12MT26/4CL	420000	3400	MP	36x56	410	254	85	130	1	-	48779	1	
20000	230	BCM-020MT324CL	580000	3200	MP	50x92	560	354	103	400	1	-	48773	2	
20000	240	BCM-020MT324CL	580000	3200	MP	52x92	560	354	103	400	1	-	48774	2	
24000	230	Q24MT32/4CL	800000	3400	MP	46x92	560	354	103	150	1	-	48776	2	
24000	240	Q24MT32/4CL	800000	3400	MP	52x92	560	354	103	150	1	-	48777	2	

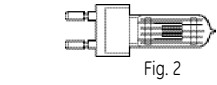

Fig. 2

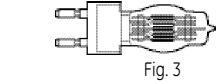

Fig. 3

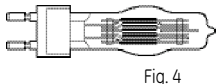

Fig. 4

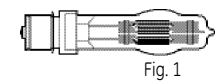

Fig. 1



Fig. 2



Fig. 3



Fig. 4

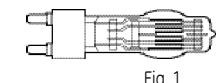

Fig. 1

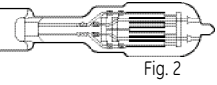

Fig. 2

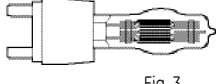

Fig. 3

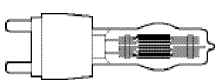

Fig. 4

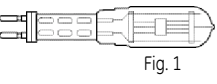

Fig. 1

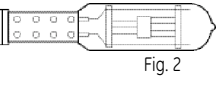
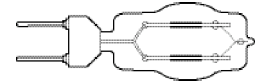

Fig. 2

SINGLE ENDED HALOGEN LAMPS

Watt	Volt	Ansi Code	LIF Code	Lumen	CCT K	Filament	Fila. H x W	Dimension A	Dim. B	Dim. C	Life (hours)	Pack Qty	Note	Product Code	Fig. No.
GX38q base - Twin filament															
1250/650	230	-	CP105	27000/13000	3050	TF	24x18.5	220	55	143	250	12	L	34056	1
1250/650	240	-	CP105	27000/13000	3050	TF	24x18.5	220	55	143	250	12	L	34024	1
1250/1250	230	-	CP30	27000/56000	3200	TF	24x18.5(x2)	220	55	143	250	12	L	30513	1
1250/1250	240	-	CP30	27000/56000	3200	TF	24x18.5(x2)	220	55	143	250	12	L	30514	1
1250/2250	230	-	CP58	27000/59000/91000	3200	TF	27.5x25/24x22	220	70	143	300	12	L	30515	1
1250/2500	240	-	CP58	27000/59000/91000	3200	TF	27.5x25/24x22	220	70	143	300	12	L	30517	1
2500/2500	230	-	CP32	5900/127000	3200	TF	27.5x25(x2)	220	70	143	300	12	L	30518	1
2500/2500	240	-	CP32	5900/127000	3200	TF	27.5x25(x2)	220	70	143	300	12	L	30519	1

Burning position VBD ±45



Watt	Volt	Ansi Code	LIF Code	Lumen	CCT K	Filament	Fila. H x W	Dimension A	Dim. B	Dim. C	Life (hours)	Pack Qty	Note	Product Code	Fig. No.
E40 base - Clear, Coil Filament															
2000	220/230	-	CP59	50000	3200	CC-8	40x7	190	30	133	300	12	W	29424	1
2000	240	-	CP59	50000	3200	CC-8	40x7	190	30	133	300	12	W	29426	1



Fig. 1



Fig. 2

E40 base - Frosted, Coil Filament															
1000	120	DKZ/DSE	-	28000	3200	CC-8	-	330	165	-	750	10	-	19926	2

DKX/DSF Burning position - any

P40s base (mogul prefocus)															
1000	240	-	T16	23000	3050	MP	17.5x17.5	180	35	87	750	12	-	30521	1
1500	120	DTA	T16	41000	3200	MP	19x17	200	40	87	300	6	-	30522	2
2000	230	-	CP53	54000	3200	MP	22x22.5	200	40	87	400	12	-	20311	2
2000	240	-	CP53	54000	3200	MP	22x22.5	200	40	87	400	12	-	20312	2

Burning position VBD ±90

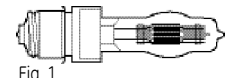

Fig. 1

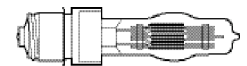
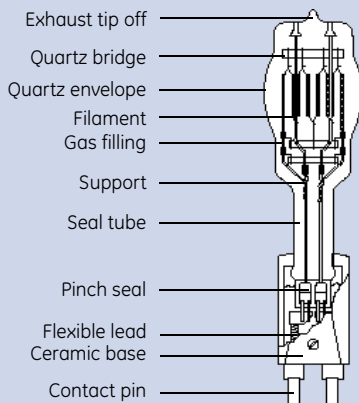
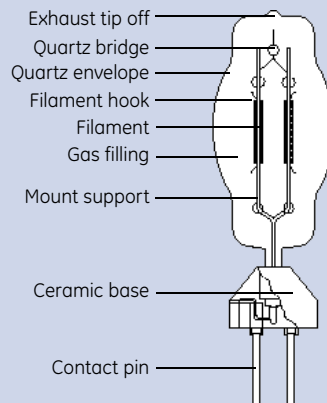

Fig. 2

A typical high wattage studio lamp



A typical 4 pin twin filament studio lamp



A typical low wattage theatre class tungsten halogen lamp

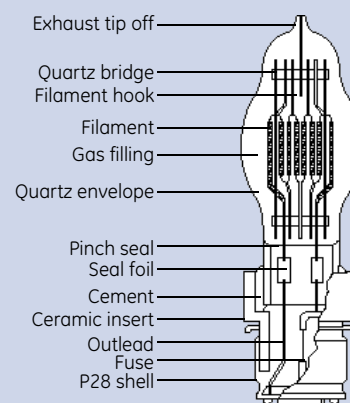

Linear Halogen Lamps

This precision range of quartz-line lamps are widely used in television broadcast studios around the world.

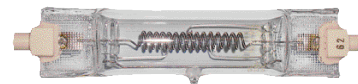

P2/27



CNBC Europe's Studio. CNBC, the 24-hour global business television news channel



Linear Halogen Lamps

Watt	Volt	LIF Code	Order Code	Lumen	CCT K	Filament	Dimension A	Dim. B	Life (hours)	Pack Qty	Note	Product Code	Fig. No.
Double-Ended Quartzline® Lamps with R7s Caps													
Length 79.4mm													
650	120	P2/6	FAD	16500	3200	CC-8	79.4	13.5	100	24	C	30325	1
800	230	P2/13	DXX	21400	3200	CC-8	79.4	13.5	75	24	C	36952	1
800	240	P2/13	DXX	21400	3200	CC-8	79.4	13.5	75	24	C	36953	1
Length 95.3mm													
1000	120	-	DXW	28000	3200	CC-8	95.3	16	150	24	-	30157	2
1000	120	-	FBY	26000	3200	CC-8	95.3	16	150	24	Frost	30374	2
Length 119.1mm - Burn Horizontal ±4°													
300	120	-	EHM	6200	2950	C-8	119.1	11	2000	6	-	43703	1
500	120	-	FCL	11100	3000	C-8	119.1	11	2000	12	-	23731	1
750	120	-	EJG	20600	3200	C-8	119.1	11	400	12	-	23756	1
800	240	P2/11	EME/Clear	22000	3200	C-8	119.1	11	150	12	-	23760	1
800	240	P2/11	EMF/Frosted	21400	3200	C-8	119.1	11	150	12	-	23761	1
1000	120	P2/28	FCM	28000	3200	C-8	119.1	11	400	12	-	23797	1
Length 142.9mm - Burn Horizontal ±4° - RX7s Caps													
2000	230	P2/27	FEX	50000	3200	CC-8	142.9	30	300	12	-	35338	2
2000	240	P2/27	FEX	50000	3200	CC-8	142.9	30	300	12	-	35339	2
2000	120	P2/27	FEY	57000	3200	CC-8	142.9	30	400	12	-	39790	2
Length 189.1mm - Burn Horizontal ±4°													
625	230	P2/10	-	16900	3200	C-8	189.1	12	300	12	-	19697	1
625	240	P2/10	-	16900	3200	C-8	189.1	12	300	12	-	19698	1
1000	230	P2/7	EKM	28000	3200	C-8	189.1	12	300	12	-	20249	1
1000	240	P2/7	EKM	28000	3200	C-8	189.1	12	300	12	-	20253	1
1250	230	P2/12	-	35000	3200	C-8	189.1	12	300	12	-	19695	1
1250	240	P2/12	-	35000	3200	C-8	189.1	12	300	12	-	19696	1

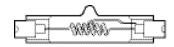

Fig. 1

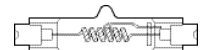

Fig. 2

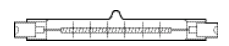

Fig. 1

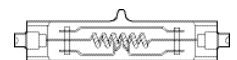

Fig. 2

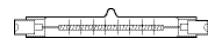
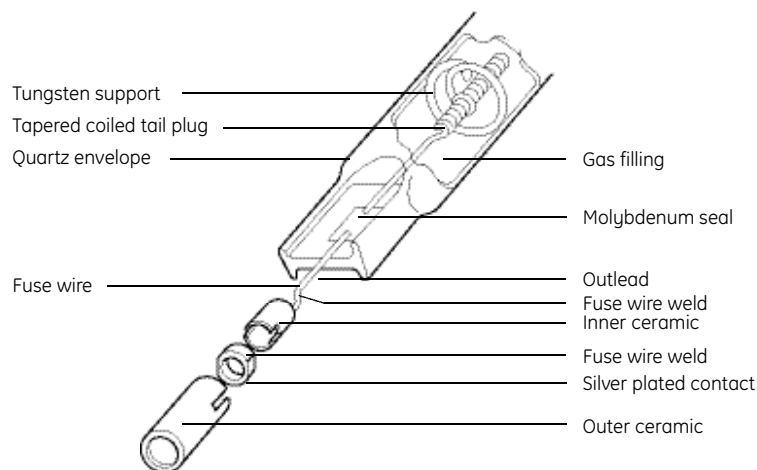

Fig. 1

End section of a typical quartz linear tungsten halogen lamp



Specialist Projector Lamps

A full range of specialist projection lamps designed to deliver excellent optical performance and reliability.



Projector



Single Ended Capsules



ELC Specialist Projector



Overhead Projector, ACCO UK



Specialist Projector Lamps

Watt	Volt Code	ANSI Code	LIF Code	Lumen position	Burning	Filament	Fila. H x W"	CCT K	Dimension A	Dim. C	Life (hours)	Cap Qty	Pack	Note	Product Code	Fig. No.
Single-ended Quartzline™- Projector Lamps																
30	6.6	EXL	-	375	-	C-8	3.3x1.3	2900	44.5	25	1000	GZ9.5	24	M	11478	-
30	10.8	DZA	-	800	BDTH	C-6	3.8x1.3	3100	51	27	400	G5.3	24	M	37346	4
50	12	BRL	A1/220	1400	BDTH	C-6	3.3x1.6	3400	44	30	50	G6.35	100	M	18234	1
100	12	FCR	A1/215	3500	BDTH	C-6	5.1x3.8	3300	44	30	50	GY6.35	100	M	14876	1
100	12	FDT	A1/261	2900	BDTH	C-6 Oval	5.8x3.8	3300	54	27	50	GZ9.5	24	M	35321	8
120	6.6	EVV	-	3150	-	C-6 Oval	6.4x3	3200	64	39	500	GZ9.5	24	M	10099	-
150	6.6	EWR	-	4100	-	C-6 Oval	6.4x4.1	3200	64	39	500	GZ9.5	24	M	11427	-
150	15	BRJ/EVB	A1/234	5000	BDTH	C-6 Oval	4.8x3.0	3400	44	30	50	G6.35	100	M	18235	1
150	24	DZE/FDS	A1/262	5000	BDTH	C-6 Oval	6.4x3.8	3250	68	33	100	GZ9.5	24	M	37695	8
150	24	FCS	A1/216	4500	BDTH	C-6 Oval	6.4x3.8	3300	51	30	50	G6.35	100	M	13598	1
175	24	EML	-	5000	BDTH	C-6	5.3x4.8	3200	54	27	125	G5.3	24	M	42612	3
250	24	EHL	A1/223	9000	BDTH	C-6 Oval	7.6x3.8	3400	57	33	50	G6.35	100	M	14874	1
275	24	FNT	-	10000	BDTH	C-6 Oval	3.5x7.1	3400	57	33	50	G6.35	100	M	18241	1
300	24	FLW	-	10200	BDTH	C-6 Oval	8.6x5.8	3500	55	33	50	GY6.35*	20	M	19886	2
400	36	EVD	A1/239	16000	BDTH	C-6 Oval	9.4x4.7	3200	60	36	50	GY6.35	25	M	41164/47420	1
400	36	-	A1/270	14500	BDTH	CC	9x4.6	-	57	36	150	GY6.35	100	M	30888	7
500	230	-	HX501	11500	BDTH	-	-	3050	60	46	300	GX9.5	24	M	35484	5
600	120	DYS	A1/264	17000	BDTH	CC-6	12.7x6.4	3200	64	37	75	GZ9.5	24	CM	32955	9
600	120	FFJ	-	17000	-	CC-8	-	3250	-	-	85	R7S	24	-	29592	-
650	230	DYR	A1/233	16500	Any	2CC-8	11.4x11.4	3200	64	37	50	GZ9.5	24	CMN	26896	10
650	240	DYR	A1/233	16500	Any	2CC-8	11.4x11.4	3200	64	37	50	GZ9.5	24	CM	26895	10
800	120	-	HX185	19000	BDTH	-	-	3050	100	53	300	GX9.5	24	M	32714	6
800	230	-	HX185	19000	BDTH	-	-	3050	100	53	300	GX9.5	24	M	30949	6
800	240	-	HX185	19000	BDTH	-	-	3050	100	53	300	GX9.5	24	M	35232	6
1000	120	BRH	-	30000	-	CC-8	-	3350	-	-	60	R7S	24	-	29604	-

* Ceramic

Watt	Volt Code	LIF Code	Lumen position	Burning	Filament A	Dimension B	Dim. C	Dim. (hours)	Life	Cap Qty	Pack	Note	Product Code	Fig. No.
------	-----------	----------	----------------	---------	------------	-------------	--------	--------------	------	---------	------	------	--------------	----------

A1 Class Projector Bulbs

150	220/230	A1/248	3000	BDTH	MP	62	16.3	40	50	G6.35	50	MT	30584	1
150	240	A1/248	3000	BDTH	MP	62	16.3	40	50	G6.35	50	MT	30585	1
300	220/230	A1/249	7200	BDTH	MP	62	16.3	40	50	G6.35	50	MNT	30587	1
300	240	A1/249	7200	BDTH	MP	62	16.3	40	50	G6.35	50	MNT	30588	1
500	220/230	A1/244	13000	BDTH	MP	75	28.5	36.5	75	GY9.5	24	MN	39643	2
500	240	A1/244	13000	BDTH	MP	75	28.5	36.5	75	GY9.5	24	MN	39644	2
650	240	A1/247	17750	BDTH	MP	75	28.5	36.5	75	GY9.5	24	MP	39650	2
800	220/230	A1/245	21500	BDTH	MP	87	28.5	44.5	75	GY9.5	24	MP	39648	2
800	240	A1/245	21500	BDTH	MP	87	28.5	44.5	75	GY9.5	24	MP	39649	2

Watt	Volt	ANSI Code	LIF Code	Lumen	CCT K	Burning position	Fila- ment	Dimension A	Dim. C	Life (hours)	Pack Qty	Note	Product Code	Fig. No.
------	------	-----------	----------	-------	-------	------------------	------------	-------------	--------	--------------	----------	------	--------------	----------

G17q cap

500	240	-	A1/241	-	3200	BDTH	BP	83	40	50	24	MNSTQ	39727	5
500	120	CBA	-	-	3200	BDTH	BP	92	44	50	24	MNT	36117	3
500	220	EPS	A1/268	-	3250	BDTH	MP	94	40	50	24	MNS	39728	4
500	240	EPS	A1/268	-	3250	BDTH	MP	94	40	50	24	MNS	39729	4

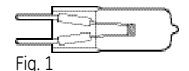

Fig. 1



Fig. 2



Fig. 3



Fig. 4



Fig. 5



Fig. 6



Fig. 7

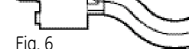

Fig. 8



Fig. 9



Fig. 10



Fig. 1



Fig. 2



Fig. 1



Fig. 2



Fig. 1

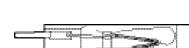

Fig. 2



Fig. 1



Fig. 2



Fig. 1



Fig. 2



Fig. 1

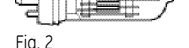

Fig. 2

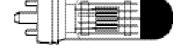

Fig. 3

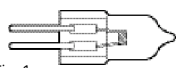

Fig. 1



Fig. 2

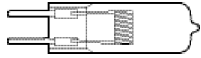

Fig. 3

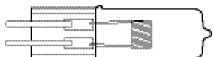

Fig. 4

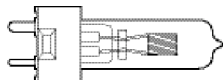

Fig. 5

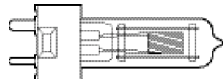

Fig. 6

Single-ended Tungsten Halogen Lamps

Watt	Volt	LIF Code	Lumen	CCT K	Filament	Dimension A	Dimension B	Dimension C	Life (hours)	Cap	Pack Qty	Product Code	Fig. No.
Low Voltage single-ended capsule													
10	6	M29/ESA	200	3200	Trans	30	10	19.5	100	G4	20	34720	1
20	6	M30/ESB	450	3200	Trans	30	10	19.5	100	G4	20	34718	1
50	12	M32	930	3000	Trans	44	12	30	4000	G6.35	20	34702	2
100	12	M28/EVA	2400	3000	C-6 Oval	44	12	30	2000	G6.35	20	34676	3
250	24	M33	8600	3000	C-6 Oval	55	13.5	33	300	G6.35	100	34768	3
250	24	M36	5750	3000	C-6 Oval	58	15	30	2000	G6.35	100	29231	4
Mains Voltage single-ended capsule													
300	120	M38	5500	2900	CC	80	28.5	45.5	2000	G9.5	24	39786	4
300	220/230	M38	5000	2900	CC	80	28.5	45.5	2000	G9.5	24	39785	4
300	240/250	M38	5000	2900	CC	80	28.5	45.5	2000	G9.5	24	39784	4
500	220/230	M40	8500	2900	SC	85	30	45.5	2000	G9.5	24	39621	5
500	240/250	M40	8500	2900	SC	85	30	45.5	2000	G9.5	24	39622	5

Double-ended lamps with R7s caps

Watt	Volt	ANSI Code	LIF Code	Application	CCT K	Filament	Dimension A	Dimension B	Life (hours)	Pack Qty	Note	Product Code	Fig. No.
Linear Projector Lamps													
200	20	DDN	-	Microfilm	3150	CC-8	60.1	13.5	-	24	M	34570	1
375	30	DWZ	A1/226	Overhead projector	3000	CC-8	80.9	10	1000	24	M	29578	1
420	120	FAL	A1/227	Overhead projector	3200	CC-8	66.5	13.5	75	24	M	29581	1

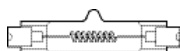

Fig. 1

Multi-Mirror® Quartzline® Projection lamps

Watt	Volt	ANSI Code	LIF Code	Application	CCT K	Filament	Dimension A	Dimension B	Working distance	Life (hours)	Cap	Pack Qty	Note	Product Code	Fign. no
MR-16 Faceted Dichroic Reflector															
30	10.8	EKZ	-	16mm projection	3100	C-6	44.45	50.67	40	200	GX5.3	20	MV	36902	1
50	13.8	DJT	-	Microfilm	3150	CC-6	44.45	50.67	155	1000	GX5.3	20	MV	44854	1
50	8	EFM	A1/229	8mm projection	3300	C-6	44.45	50.67	32	50	GZ6.35	20	MV	21276	2
75	12	EFN	A1/230	8mm projection	3350	CC-6	44.45	50.67	32	50	GZ6.35	20	MV	21277	2
80	19	DDM	-	Slide projection	3350	CC-6	44.45	50.67	155	50	GX5.3	20	MV	43206	1
80	21	DDS	-	Microfilm	3125	CC-6	44.45	50.67	165	1000	GX5.3	20	MV	43988	1
85	13.8	DED	-	Microfilm	3150	CC-6	44.45	50.67	165	1000	GX5.3	20	MV	43950	1
100	12	EFP	A1/231	8mm projection	3350	CC-6	44.45	50.67	32	50	GZ6.35	20	MV	21278	2
150	15	EFR	A1/232	8mm projection	3350	CC-6	44.45	50.67	32	50	GZ6.35	20	MV	21279	2
150	20	DDL	-	Microfilm	3150	CC-6	44.45	50.67	200	500	GX5.3	20	MV	43537	1
150	21	ELD/EJN	-	Microfilm	3350	CC-6	44.45	50.67	165	40	GX5.3	20	MV	38306	1
150	21	EJM	-	8mm projection	3350	CC-6	44.45	50.67	40	40	GX5.3	10	MV	29151	1
150	21	EKE	-	8mm projection	3250	CC-6	44.45	50.67	45	200	GX5.3	20	MV	35200	1
200	24	EKX	-	Microfilm	3400	CC-6	44.45	50.67	145	25	GX5.3	20	MV	36899	1
200	24	EJL	A1/252	16mm, Colour printer	3400	CC-6	44.45	50.67	32	50	GX5.3	20	MV	29150	1
250	24	ELC	A1/259	16mm, Colour printer	3400	CC-6	44.45	50.67	30	50	GX5.3	20	MV	37462	1
250	24	ELC500	-	Disco	3250	CC-6	44.45	50.67	30	500	GY5.3	20	MV	15377	1
250	120	ENH	-	Slide projection	3250	CC-8	44.45	50.67	155	175	GY5.3	20	MV	38686	3
300	120	ELH	-	Slide projection	3350	CC-8	44.45	50.67	155	35	GY5.3	10	MV	38476	1
300	120	ENG	-	Slide projection	3450	CC-8	44.45	50.67	155	15	GY5.3	10	MV	38685	3

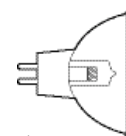

Fig. 1

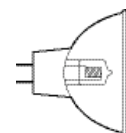

Fig. 2

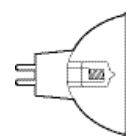

Fig. 3

Watt	Volt	ANSI Code	LIF Code	Application	CCT K	Filament	Dimension A	Dimension B	Working distance	Life (hours)	Cap	Pack Qty	Note	Product Code	Fign. no
MR-16 Dichroic Reflector															
80	19	EJY	-	Fibre optics	3400	CC-6	44.45	50.67	40	25	GX5.3	20	MV	32886	1
80	30	ELB	-	8mm projection	3400	CC-6	44.45	50.67	32	18	GX5.3	20	MV	37412	1
150	21	EJA	-	Fibre optics	3350	CC-6	44.45	50.67	28	40	GX5.3	20	MV	32882	2
150	21	EJV	-	8mm projection	3350	CC-6	44.45	50.67	45	40	GX5.3	20	MV	32831	2

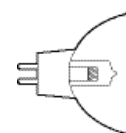

Fig. 3

Watt	Volt	ANSI Code	LIF Code	Application	CCT K	Filament	Burn Position	Dim. A	Dim. B	Working distance	Life (hours)	Cap	Pack Qty	Note	Product Code	Fign. no
MR-16 Dichroic Reflector																
150	21	DNF	A1/266	8mm projection	3400	CC-6	Horiz	45	50	40	25	GX5.3	20	MV	32886	1

Multi-Mirror® Quartzline® Projection lamps

Watt	Volt	ANSI Code	Application	CCT K	Filament	Dimension A	Dimension B	Working distance	Life (hours)	Cap Qty	Pack	Note	Product Code	Fig. no
MR-16 Faceted Dichroic Reflector														
25	13.8	FHX	Microfilm	3200	CC-6	44.45	50.67	110	250	GX5.3	20	MV	47914	1
42	10.8	EPT	Fibre optics	2900	C-6	44.45	50.67	40	8000	GX5.3	20	MV	41729	1
50	12	ENL	Fibre optics*	3050	C-6	44.45	50.67	40	4000	GX5.3	20	MV	25475	1
50	13.8	EPZ	Microfilm	3150	CC-6	44.45	50.67	110	1000	GX5.3	20	MV	43948	1
50	13.8	FML	Microfilm	3150	CC-6	44.45	50.67	215	1000	GX5.3	20	MV	14887	1
80	19	ENW/ENC	8mm projection	3200	CC-6	44.45	50.67	45	200	GX5.3	10	MV	40248	1
90	14.5	EPV	Microfilm	3150	CC-6	44.45	50.67	155	500	GX5.3	20	MV	41882	1
90	14.5	EPX	Microfilm	3150	CC-6	44.45	50.67	165	500	GX5.3	20	MV	42614	1
150	120	ESD	Enlarger, projection	3350	CC-8	44.45	50.67	45	12	GY5.3	20	MV	43756	2
150	120	EZK	Camera light	3200	CC-8	44.45	50.67	-	200	GY5.3	20	MV	15477	2
200	24	EWf	Overhead projection	3300	CC-8	44.45	50.67	300	50	GX5.3	20	MV	11132	2
200	82	EYA	Enlarger	3300	CC-8	44.45	50.67	-	50	GY5.3	20	MV	13152	2
250	82	EVW	Overhead projection	3300	CC-8	44.45	50.67	300	50	GY5.3	20	MV	11110	2
250	120	EXX	Camera light	3300	CC-8	44.45	50.67	-	25	GY5.3	20	MV	11750	2
340	36	ERV	Overhead projection	3300	CC-8	44.45	50.67	300	75	GY5.3	20	MV	41874	2
360	100	EPW	Overhead projection	3250	CC-6	44.45	50.67	300	75	GY5.3	20	MV	41702	2
360	82	ENX	Overhead projection	3300	CC-8	44.45	50.67	300	75	GY5.3	20	MV	41705	2
410	82	FXL	Overhead projection	3300	CC-8	44.45	50.67	300	38	GY5.3	20	MV	21613	2

* Display lighting

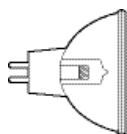

Fig. 1

MR-11 Faceted Dichroic Reflector														
28	13.8	FLT	Microfilm	3050	CC-6	40	35.3	76 or 175	500	GZ4	10	MV	26261	1
MR-13 Faceted Dichroic Reflector														
250	82	EXY	Slide projection	3200	CC-8	44.4	42.4	150	200	GX5.3	10	MV	12097	2
225	68	EZF/EZJ	Colour printer		CC-8	44.4	42.4	-	500	GX5.3	10	MV	15832	2
300	82	EXR	Slide projection	3350	CC-8	44.4	42.4	150	35	GX5.3	10	MV	12092	2
300	82	EXW	Slide projection	3450	CC-8	44.4	42.4	150	15	GX5.3	10	MV	12095	2
300	82	FHS	Slide projection	3300	CC-8	44.4	42.4	150	70	GX5.3	10	MV	47614	2

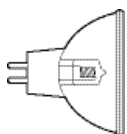

Fig. 2

G7.9 Vented Cap Reflector Quartzline®

Watt	Volt	ANSI Code	LIF Code	Application	Burning position	CCT K	Filament	Dimension A	Dimension B	Working distance	Life (hours)	Cap Qty	Pack	Product Code	Fig. no
MR-14 Dichroic Reflector															
50	16	ELS/ELR	-	Microfilm	BDTH	3100	CC-6	36	44.4	120	650	GX7.9	24	41885	1
250	24	EMM/EKS	A1/258	16mm projection	BDTH	3400	CC-6	42.2	44.4	67	50	GX7.9	24	40017	1

Gemini and Marc lamps should be operated with the plane of the reflector vertical. These lamps should not be operated for periods of less than three minutes since short operating cycles reduce life and degrade performance.

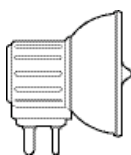

Fig. 1

Discharge Lamps

New CSR & CSD lamps have been introduced to increase the range of discharge products for use in Stage & Studio applications.

GE UV Control lamps are the newest addition to the GE hot restrike line of entertainment metal halide lamps.

- 95% Reduction of UVB and UVC
- Greater than 85% reduction of total UV emissions
- 5600 Kelvin colour temperature
- No reduction in lumen output



CSD 250/2

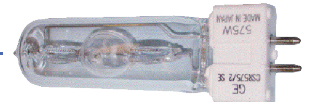

CSR 575/2



MGM Grand, Las Vegas, Discharge lighting being used in one of the top Entertainment resorts.

Discharge Lamps

Watt	Volt	Description	Finish	CCT K	Lumen	Burning position	Life (hours)	Pack Qty	Cap	Product Code	Fig. No.
Single Ended Hot Restrike											
125	80	CSR125/SE/HR	CLEAR	5600	9400	UNIVERSAL	200	10	GZY9.5	48461	1
200	80	CSR200/SE/HR	CLEAR	5600	15000	UNIVERSAL	200	10	GZY9.5	48462	1
400	70	CSR400/SE/HR	CLEAR	5900	32000	UNIVERSAL	750	10	GZZ9.5	21853	1
575	95	CSR575/SE/HR	CLEAR	6000	48000	UNIVERSAL	750	10	G22	48463	2
800	95	CSR800/SE/HR	CLEAR	6000	64000	UNIVERSAL	750	6	G22	22495	2
1200	100	CSR1200/SE/HR	CLEAR	6000	110000	UNIVERSAL	750	6	G38	48464	3
2500	115	CSR2500/SE/HR	CLEAR	6000	220000	UNIVERSAL	500	6	G38	48465	4
4000	200	CSR4000/SE/HR	CLEAR	6000	380000	UNIVERSAL	500	6	G38	48466	4
6000	123	CSR6000/SE/HR	CLEAR	6000	540000	UNIVERSAL	300	6	G38	48467	5
12000	160	CSR12000/SE/HR	CLEAR	6000	1100000	UNIVERSAL	250	4	G38	48468	5
18000	225	CSR18000/SE/HR	CLEAR	6000	1650000	UNIVERSAL	250	1	G38	22496*	5
18000	225	CSR18000S/DE	CLEAR	6000	1650000	HORIZONTAL±15°	300	6	30x70 cylinder	48460	5
Single Ended Cold Start											
150	95	CSR 152/SE	CLEAR	5000	10000	UNIVERSAL	2000	10	GY9.5	22862	1
250	90	CSD250/2/SE	CLEAR	8500	18000	UNIVERSAL	2000	10	GY9.5	27817	1
575	95	CSR575/2/T/SE	CLEAR	7200	49000	UNIVERSAL	1000	10	GX9.5	49492	1
575	95	CSR575/2/SE	CLEAR	7200	49000	UNIVERSAL	1000	10	GX9.5	15378	2
700	72	CSR700/2/SE	CLEAR	7200	55000	UNIVERSAL	1000	10	G22	49491	2
1200	100	CSR1200/2/SE	CLEAR	7200	110000	UNIVERSAL	1000	6	G22/30x53	49490	2
Double Ended Hot Restrike											
200	80	CSR200/DE	CLEAR	6000	16000	HORIZONTAL±15°	300	10	X515	48450	1
400	49E	CSR400/S/DE	CLEAR	7500	26000	ANY	750	10	SFc 10-4 SI/M4	22478*	1
575	95	CSR575/DE	CLEAR	6000	49000	HORIZONTAL±15°	750	10	SFc 10-4 SI/M4	48451	2
700	70E/73M	CSR700/S/DE	CLEAR	7500	59000	ANY	750	10	SFc 10-4 SI/M4	22493*	2
1200	95E/100M	CSR1200S/DE	CLEAR	6000	110000	ANY	750	10	SFc 10-4 SI/M4	22494*	2
1200	100	CSR1200/DE	CLEAR	6000	110000	HORIZONTAL±15°	750	10	SFc 10-5-6 Sleeve/Thd.Pin M6	48453	2
2500	115	CSR2500/DE	CLEAR	6000	240000	HORIZONTAL±15°	500	6	Sta 21-12	48454	3
4000	200	CSR4000/DE	CLEAR	6000	410000	HORIZONTAL±15°	500	6	Sta 21-12	48455	3
6000	125	CSR6000/DE	CLEAR	6000	570000	HORIZONTAL±15°	300	10	25x51 cylinder LEAD 165mm	48456	3
12000	160	CSR12000/DE	CLEAR	6000	1100000	HORIZONTAL±15°	300	10	30x70 cylinder LEAD 165mm	48457	4
18000	225	CSR18000/DE	CLEAR	6000	1650000	HORIZONTAL±15°	300	6	30x70 cylinder LEAD 165mm	48459	4
18000	225	CSR18000S/DE	CLEAR	6000	1650000	HORIZONTAL±15°	300	6	30x70 cylinder LEAD 165mm	48460	4
Short Arc											
700	70	CSR700SA	CLEAR	5600	58000	UNIVERSAL/LEADDOWN	750	10	GY9.5	15380	1
1200	100	CSR1200SA	CLEAR	6000	96000	UNIVERSAL/LEADDOWN	750	6	GY22	21849	1
1800	TBA	CSR2000SA	CLEAR	5600	155000	UNIVERSAL/LEADDOWN	750	6	GY22	21801	1

Discharge lamps must be operated in an enclosed fixture.
Discharge lamps require control gear.

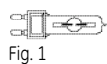

Fig. 1

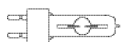

Fig. 2



Fig. 3



Fig. 4

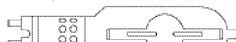

Fig. 5



Fig. 1



Fig. 2

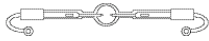

Fig. 3



Fig. 4

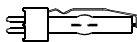
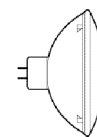

Fig. 1

Ceramic Metal Halide (CMH)

Watt	Volt	Description	Lens Style	CCT K	CRI	Beam	Beam 10%	Beam 50%	MPBC	Life (hours)	Pack Qty	Cap	Product Code
CMH PAR64 – Architainment													
150	95	CMH150/PAR64/830/GX16d/SP 1/6	Stipple	3000	80+	Narrow	9x9	4x4	240000	8000	6	GX16d	16958
150	95	CMH150/PAR64/830/GX16d/MFL 1/6	8-Bar	3000	80+	Medium	18x15	13x11	80000	8000	6	GX16d	16959
150	95	CMH150/PAR64/830/GX16d/WFL 1/6	12-Bar	3000	80+	Wide	25x20	18x15	33000	8000	6	GX16d	16960
150	100	CMH150/PAR64/942/GX16d/SP	Stipple	4200	90+	Narrow	9x9	4x4	240000	8000	6	GX16d	16961
150	100	CMH150/PAR64/942/GX16d/MFL	8-Bar	4200	90+	Medium	18x15	13x11	80000	8000	6	GX16d	16962
150	100	CMH150/PAR64/942/GX16d/WFL	12-Bar	4200	90+	Wide	25x20	18x15	33000	8000	6	GX16d	16963



Discharge lamps must be operated in an enclosed fixture.
Discharge lamps require control gear.

CMH PAR 56 Architainment													
150	95	CMH150/PAR56/830/GX16d/SP	Stipple	3000	80+	Narrow	68X63	14X19	80000	5000	6	GX16d	22693*
150	95	CMH150/PAR56/830/GX16d/MFL	8-Bar	3000	80+	Medium	74X65	19X22	60000	5000	6	GX16d	22694*
150	95	CMH150/PAR56/830/GX16d/WFL	12-Bar	3000	80+	Wide	81X67	29X23	50000	5000	6	GX16d	22696*
150	100	CMH150/PAR56/942/GX16d/SP	Stipple	4200	90+	Narrow	68X63	14X19	80000	5000	6	GX16d	22697*
150	100	CMH150/PAR56/942/GX16d/MFL	8-Bar	4200	90+	Medium	74X65	19X22	60000	5000	6	GX16d	22700*
150	100	CMH150/PAR56/942/GX16d/WFL	12-Bar	4200	90+	Wide	81X67	29X23	50000	5000	6	GX16d	22702*

* Available early 2006

CSR UVC lamps

Watt	Cap	CCT K	Lumens	Order Description	Avg. Rated Life	Pack Qty	Product Code
575	G22	5600	49000	CSR575/SE/HR/UV-C	750	10	40460
800	G22	5600	64000	CSR800/SE/HR/UV-C	1000	10	22495
1200	G22	5600	110000	CSR1200/SE/HR/UV-C	750	6	27746
2500	G22	5600	220000	CSR2500/SE/HR/UV-C	500	6	40482
4000	G22	5600	380000	CSR4000/SE/HR/UV-C	500	6	27765
6000	G22	5600	540000	CSR6000/SE/HR/UV-C	300	6	40492

CSS



Fig. 1



Fig. 2

Watt	Volt	Order Code	Lumen	CCT K	CRI	Dimension A	Dim. B	Dim. C	Life (hours)	Pack Qty	Product Code	Fig. No.
Base: GY9.5 - Burning position: VBD±90												
140	85	CSS150/850/GY9.5	10000	5000	80	48	22	30	1000	10	34813	1
575	95	CSS575/855/GY9.5	40250	5500	85	94	22	52	500	10	34822	2

CSI/CID Lamps

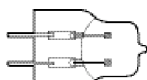

Fig. 3

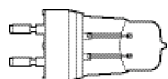

Fig. 4

Watt	Volt	Order Code	Lumens 100 hrs	Lumen maintenance	CCT K	CRI	Life (hours)	Pack Qty	Product Code	Fig. No.
(Compact Source Iodide/Compact Iodide Daylight)										
Special bipin base (2 pin 9mm) - Burning position: VBD±90										
400	100	99-0201 CSI	32000	85% at 500 hrs	4000±400	80	500	1	30555	3
G22 base (medium bipost)										
Burning position: VBD±90										
1000	77	99-0221 CSI	90000	85% at 500 hrs	4000±400	80	500	1	30558	4

Discharge lamps must be operated in an enclosed fixture.
Discharge lamps require control gear.

Watt	Volt	Order Code	Axial intensity Cd	Angle 1/2	Angle 1/10	CCT K	CRI	Life (hours)	Pack Qty	Product Code	Fig. No.
G38 base (mogul bipost)											
Burning position: HOR±90											
1000	77	99-1222 CSI CS	1350000	6	18	3800±500	80	3500	1	29333	4
1000	77	99-1422 CSI HR	1350000	6	18	3800±500	80	3500	1	29336	4

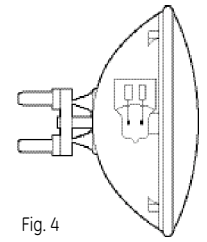

Fig. 4

Watt	Volt	Order Code	Lumens 100 hrs	Lumen maintenance	CCT K	CRI	Life (hours)	Pack Qty	Product Code	Fig. No.
Special Bipin base										
Burning position: VBD±90										
200	70	99-0211 CID	14000	90% at 150 hrs	5500±400	85	150	1	30560	5
G22 base (medium bipost)										
Burning position: VBD±90										
575	95	99-0415 CID	40250	90% at 500 hrs	5500±400	85	500	1	30563	1
1000	77	99-0222 CID	70000	90% at 500 hrs	5500±400	85	500	1	30561	2

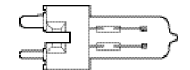

Fig. 5

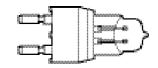

Fig. 1

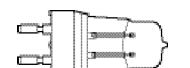

Fig. 2

Watt	Volt	Order Code	Lumen maintenance	Lumen	CCT K	CRI	Life (hours)	Pack Qty	Product Code	Fig. No.
G38 base (mogul bipost)										
Burning position: VBD±90										
2500	100	99-0431 CID HR	200000	90% at 350 hrs	5500±400	85	350	1	30567	3

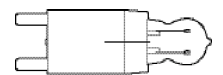

Fig. 3

Watt	Volt	Order Code	Axial intensity Cd	Angle 1/2	Angle 1/10	CCT K	CRI	Life (hours)	Pack Qty	Product Code	Fig. No.
G38 base (mogul bipost)											
Burning position: HOR±90											
1000	77	99-1225 CID CS	850000	8	20	5500±400	85	1500	1	30360	4
1000	77	99-1425 CID HR	850000	8	20	5500±400	85	1000	1	30371	4
1200	100	99-1435 CID HR	820000	9	18	5500±400	85	1000	1	30372	4

Discharge lamps must be operated in an enclosed fixture.
Discharge lamps require control gear.

Circuit diagrams

200 Watt CID Hot-Restart Lamp Circuit Diagram

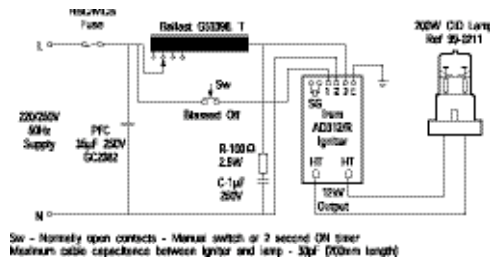

400 Watt CSI Lamp Circuit Diagram

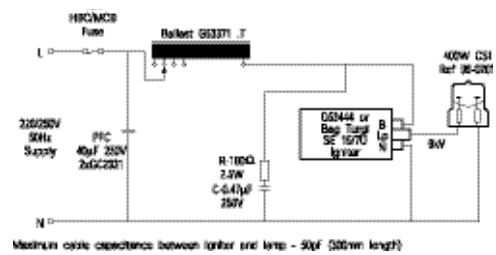

575 Watt CID Lamp Circuit Diagram

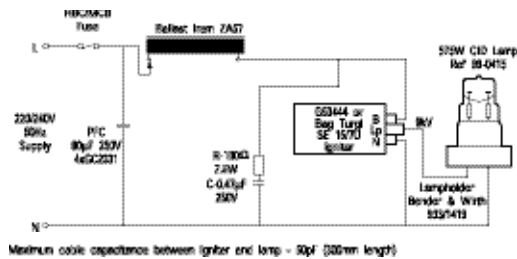

1000 Watt CSI Lamp Circuit Diagram

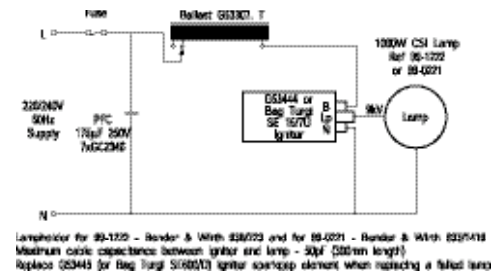

1000 Watt CID Lamp Circuit Diagram

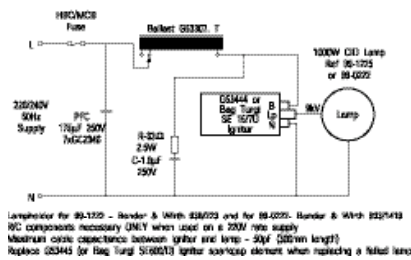

1000 Watt CSI/CID Hot-Restart Lamp Circuit Diagram

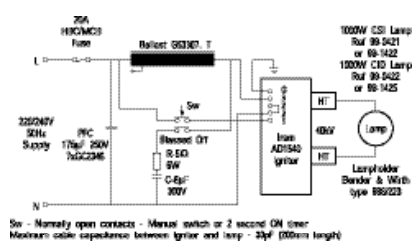

1200 Watt CID Hot-Restart Lamp Circuit Diagram

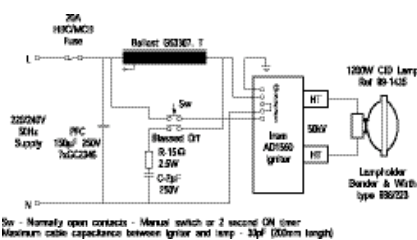

2500 Watt CID Hot-Restart Lamp Circuit Diagram

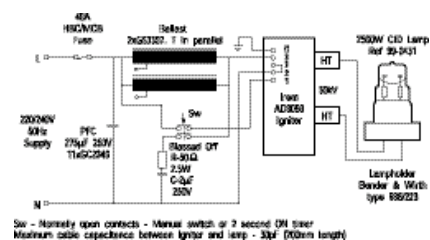

Cinema Lamps

Watt	Order Code	Description	Life (hours)	Pack Qty	Product Code	Fig.No.
Cinema High Lumen Biax™						
55	F55BX/CINEMA32	Indoor	10000	10	15811/41869	1
55	F55BX/CINEMA56	Daylight	10000	10	15814/41873	1
Cinema Plus Biax™						
55	F55BX/CINPLUS/32		40	10	22084/41903	1
55	F55BX/CINPLUS/55		40	10	22085/41911	1
Cinema Lamps 32 & 55						
T8						
32	F32T8/CIN55/CVG	Daylight	20000	36	47882	2
32	F32T8/CIN32/CVG	Indoor	20000	36	47881	2
T12						
35	F20T12/CINEMA32/HO/CVG	Indoor	7000	24	15775	2
35	F20T12/CINEMA55/HO/CVG	Daylight	7000	24	15776	2
75	F40T12/CINEMA32/HO/CVG	Indoor	12000	30	15782	2
75	F40T12/CINEMA55/HO/CVG	Daylight	12000	30	15783	2
85	F72T12/CINEMA32/HO/CVG	Indoor	12000	15	15785	2
85	F72T12/CINEMA55/HO/CVG	Daylight	12000	15	15786	2
110	F96T12/CINEMA32/HO/CVG	Indoor	12000	15	15794	2
110	F96T12/CINEMA55/HO/CVG	Daylight	12000	15	15798	2

Fluorescent Cinema Lamps - life on rapid start ballast
 CVG = These lamps feature GE's exclusive CovRguard coating

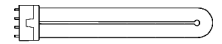



Watt	Order Code	Description	Dimension A	Life (hours)	Pack Qty	Product Code	Fig.no
Blacklight Blue (produce long wave ultra-violet light)							
T12							
20	F20T12/BLB	Blacklight Blue	600	9000	6	34747	2
40	F40BLB	Blacklight Blue	1200	20000	6	25618	2

Explanation of codes

Lamps listed in this catalogue are those designed for use as follows:

A1 Prefix – L.I.F. (Lighting Industries Federation) reference indicates lamps which were primarily designed for use with slide, film and overhead projectors.

ANSI Codes – These are 3-letter codes assigned by the American National Standards Institute. They provide a system for assuring mechanical and electrical interchangeability among similarly coded lamps from various manufacturers.

CP Prefix – Lamps designed for use in conjunction with film balanced for 3200K. These are single ended types intended for use in Fresnel/ellipsoidal luminaires etc.

P2 Prefix – Again for use with 3200K film stock for open faced luminaires and video sun guns.

P1 Prefix – For use with 3400K film stock.

T Prefix – Lamps intended for theatre luminaire applications. These are of lower colour temperature (2900 - 3050K) and longer life than the often similar CP types above.

C.S.I. – Discharge lamps with a colour temperature of around 4000K for outside broadcast and follow spot use.

C.I.D. – Discharge lamps with a colour temperature of 5500–6000K for location filming and applications such as disco lighting where a very bright compact source is required.

Special and Experimental Lamps

In addition to these standard ranges, a number of similar types are available to special order and in most cases, a minimum order quantity will apply. These include non-standard voltage ranges of some types e.g. 100V, 100/115V, 120V and also a number of types which have the GE "HX" or "THE" prefix.

Lamp Bases

The listings use the IEC International designations for lamp bases. Where appropriate, alternative local descriptions are appended.

Incandescent tungsten halogen lamps

Filament Format

The listings use the following codings for filament shape:

S.C. – Axial Single Coil – equivalent to ANSI C8

C.C. – Axial Coiled Coil – equivalent to ANSI CC8

M.P. – Monoplane Grid – equivalent to ANSI C13

B.P. – Biplane Grid – equivalent to ANSI C13D

T.F. – Twin Monoplane Grid – equivalent to ANSI 2C13

S.C.H – Single Coil Hexagonal – equivalent to ANSI 6-C8

S.C.S – Single Coil Square – equivalent to ANSI 4-C8

CP Range of Lamps for Fresnel and Spotlight Fittings

As the result of extensive and sustained development work, much of it original, GE is able to offer a comprehensive range of lamps of quartz construction, operating on the tungsten halogen principle for all Television Studio, 'motion picture', and Theatre lighting purposes.

GE has been strongly supported by the television and film industries in its decision to discontinue glass lamps for studio lighting purposes. This is because the industry has appreciated the financial advantages of quartz halogen lamps, their reliability and virtually constant colour temperature.

The increase in the use of the lamps we now manufacture is due to the GE policy of exploiting the important advantages

of compact size offered by quartz halogen construction.

As a result GE is able to supply quartz halogen lamps for use in Fresnel and spotlight fittings from 300 watts to 24,000 watts. These lamps employ a wide range of commonly accepted bases. This gives fittings manufacturers a comprehensive range of compact lamps and permits the construction of smaller, lighter and more efficient luminaires.

Glossary of basic product information

Rated Average Life

Average life ratings of Projection Lamps are based on closely controlled laboratory tests of lamps, at their rated voltage, over a long period of production time. Rated Average Life is not necessarily the same as service life; mechanical shock and vibration, voltage fluctuation, temperature and other environmental factors may result in shorter service life. As with any average value, some individual lamps may operate longer, and some may operate shorter, than their Rated Average Life. (Supply voltage variation can significantly affect lamp life; see comments under Lamp Life Ratings, page 107).

'T' Class Lamps for Theatre Spotlight Fittings

With this group of lamps GE is continuing their policy of developing quartz halogen lamps. These lamps operate at a lower colour temperature than the CP range. An average life of a remarkable 750 hours is achieved for most of the GE range. Similar cost savings to those offered by quartz halogen CP lamps are now presented by the quartz halogen 'T' range.

Typical Working Distance

For Multi-Mirror® and other reflector lamps and MARC™ lamps, the Working Distance shown is the distance from the front surface of the reflector rim to the film plane, in the optical system for which the lamp was first designed. In most cases, it provides a uniform plane of light for the intended aperture.

Light Centre Length (LCL)

This dimension defines the location of the filament in relation to the lamp base. It is measured from the geometric centre of the filament to a specified point on, or plane through, the base. Light Centre Length is subject to manufacturing tolerances.

Maximum Overall Length (MOL)

This dimension includes the lamp bulb and all rigid parts of the base. Since the listed lengths include maximum tolerances, actual lamps are generally slightly shorter.

Approximate Initial Lumens

The value shown is based on spherical photometry, at rated voltage, of lamps that have been seasoned for

approximately 15% (or a minimum of 2 hours) or more of their rated average life.

Approximate Colour Temperature

The radiation within the visible spectrum from tungsten filament lamps is similar in spectral distribution to that from a "blackbody" at specific colour temperatures. The Colour Temperatures shown are approximate initial values in Kelvin (K) for lamps operated at rated voltage. As the spectral distribution of MARC lamps does not conform to that of a "blackbody", the values shown are 'correlated' colour temperatures expressed in Kelvin.

Important Notice

This catalogue contains accumulated data to November 2003. Additional information is constantly being uncovered through research and testing, which may modify the data given herein. This is particularly true of newer lamps. For the latest lamp design data and information, contact your General Electric Lamp Representative. The data and suggested applications contained in this catalogue, as well as any additional information our representative may be able to furnish, are for general information only and are not intended and should not be taken as representations or warranties as to the suitability of a lamp for any particular attention or use in any particular equipment, nor are our representatives authorised to make any such representations or give any such warranties. Applications and conditions of use are many and varied, and beyond our control. We cannot possibly have the same degree of knowledge that the purchaser has with respect to the design of their equipment and the conditions of its use. Therefore, it is up to the purchaser to make their own determination as to the suitability of a lamp for his intended application or use and to assume the responsibility for that determination. General Electric desires to supply the best possible products at all times. For this reason, General Electric reserves the right to make changes in its products when it believes such changes will improve its products.



Operating Temperature of Tungsten Halogen Studio Lamps

The following maximum and minimum temperatures are suggested for optimum life. Operation outside these figures will not necessarily cause immediate failure but will affect life adversely to an increasing extent.

Seal – 450° C maximum - Above this figure the sealing foil oxidises at a rate increasing with temperature and is frequently the cause of short life due to seal failure.

Bulb - 250° - 800° C – Outside this range the halogen cycle becomes less efficient and blackening may occur.

Temperatures above 1200° C will cause the bulb to soften.

Pins - 350° C maximum – Above this figure the plating on the pins may lose adhesion and the contact will deteriorate. Such deterioration may form local hot spots which rapidly worsen and may result in arcing and irreparable damage to both lamp and holder. Should signs of this be evident on removal of a failed lamp, it is important that a good contact is restored by replacing the lampholder before the next lamp is fitted. Otherwise the new lamp will rapidly fail in a similar manner."

Fusing of Tungsten Halogen Studio and Theatre Lamps

A lamp normally fails at end of life by fusing of the filament. Often an arc then forms and as there is little resistance to limit the current this rises to a very high value which if maintained can result in a serious overload on the envelope and seals. This might result in the lamp shattering. A quick acting high breaking capacity fuse must be connected in the supply line in all applications. Suitable types are given in BS88 (IEC 60269), IEC 60127 or IEC 60241.

Discharge lamps

Even with all the advances which have been made in tungsten halogen technology in recent years there are still occasions, particularly whilst working on location, when handling the number of fittings required to give an acceptable illumination level can be a logistical headache.

One GE metal halide discharge lamp can provide more light than three tungsten halogen lamps of the same rating. That means one third the power consumption and one third the number of fittings to transport and aim. The potential for major cost savings is clear. GE Lighting has led the way in adapting discharge lamps for use in the performing arts. The company was the first and for many years the only manufacturer to offer metal halide lamps in the compact, single ended capsule format. The minimal dimensions of these lamps can be incorporated into fittings which are much smaller than corresponding luminaires using double ended

lamps of the same power. With a near point light source excellent optical control is possible.

Compact iodide lamps are also available in a sealed beam format. With the light source carefully positioned in the reflector, optimum optical performance is guaranteed. The nitrogen filling gas in the outer bulb prevents oxygen attacking the seal of the inner capsule and so increases the life of the lamp dramatically.

All CID discharge studio and stage lamps are dimmable to 50% of peak lumens and the great majority are available in hot re-strike versions for applications where frequent changes in lighting levels are required. All lamps will re-strike within ten minutes of switch off.

Operating Temperature of Discharge Studio Lamps

The following maximum and minimum temperatures are suggested for optimum life. Operation outside of these figures will not necessarily cause immediate failure but will effect life adversely to an increasing extent.

Cap/bulb interface capsule lamps - 450° maximum
Above this figure the sealing foil oxidises at a rate increasing with temperature and is frequently the cause of short life due to seal failure.

Bulb

capsule lamps 700° - 1000°C

sealed beam lamps 150° - 400°C

Above 1000°C, quartz may devitrify, which will cause the arc tube to leak, loss of dose will cause the arc tube to operate below the minimum temperature, the metal halides will not vaporise as required, and lamp performance will be impaired.

Pins - 350°C maximum

Above this figure the plating on the pins may lose adhesion and the contact will deteriorate. Such deterioration may form local hot spots which rapidly worsen and may result in arcing and irreparable damage to both lamp and holder. Should signs of this be evident on removal of a failed lamp, it is important that a good contact is restored by replacing the lampholder before the next lamp is fitted, otherwise the new lamp will rapidly fail in a similar manner.

N.B. For sealed beam lamps - to ensure that the above conditions are met, it is important that the lamp does not operate above 400°C even in an enclosed fitting.

Fusing of Discharge Studio and Theatre Lamps

A quick acting high breaking capacity fuse must be connected in the supply line in all applications. Suitable types are given in BS88 (IEC 60269), IEC 60127 or IEC 60241.

Showbiz lamps

Turn on time of studio lamps

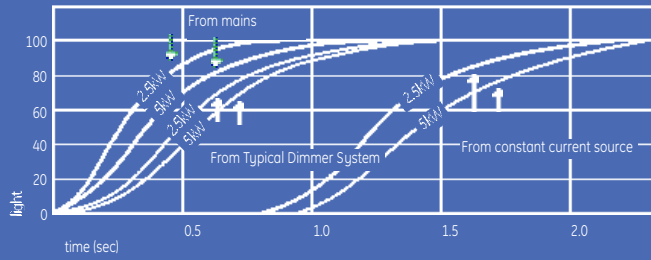

Fusing of Tungsten Halogen Studio and Theatre Lamps

Lamp power (watts)	Fuse (rated current) (amps)		
	100-115V	115-130V	220-250V
500	6	6	4
650	10	6	4
1000	16 (15 UK)	10	6
1500	20	16 (15 UK)	10
2000	25 (30 UK)	25 (30 UK)	10
2500	35 (30 UK)	25 (30 UK)	16 (15 UK)
5000	63 (60 UK)	50	25 (30 UK)
10000	125	100	50

Variation of light output and wattage with applied voltage for a typical studio lamp

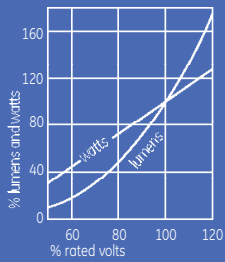

Colour temperature variation with voltage for typical studio lamp

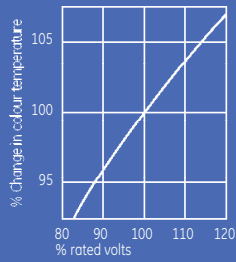

Typical life variation against operation voltage

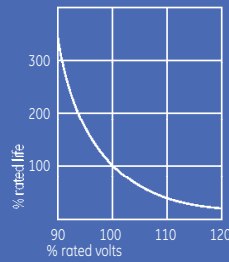

Spectral distribution of luminous flux (lumens) for typical theatre and studio lamp

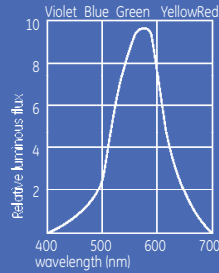

Total spectral energy distribution of typical studio lamp

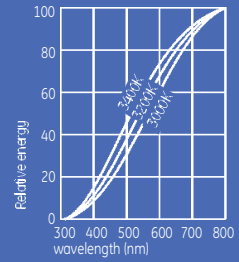

Spectral distribution of luminous flux (lumens) for CSI discharge lamps

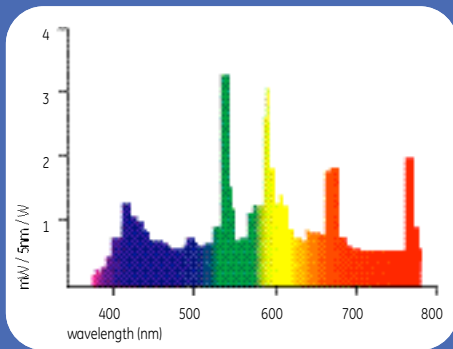

Spectral distribution of luminous flux (lumens) for CID discharge lamps

